

Side View

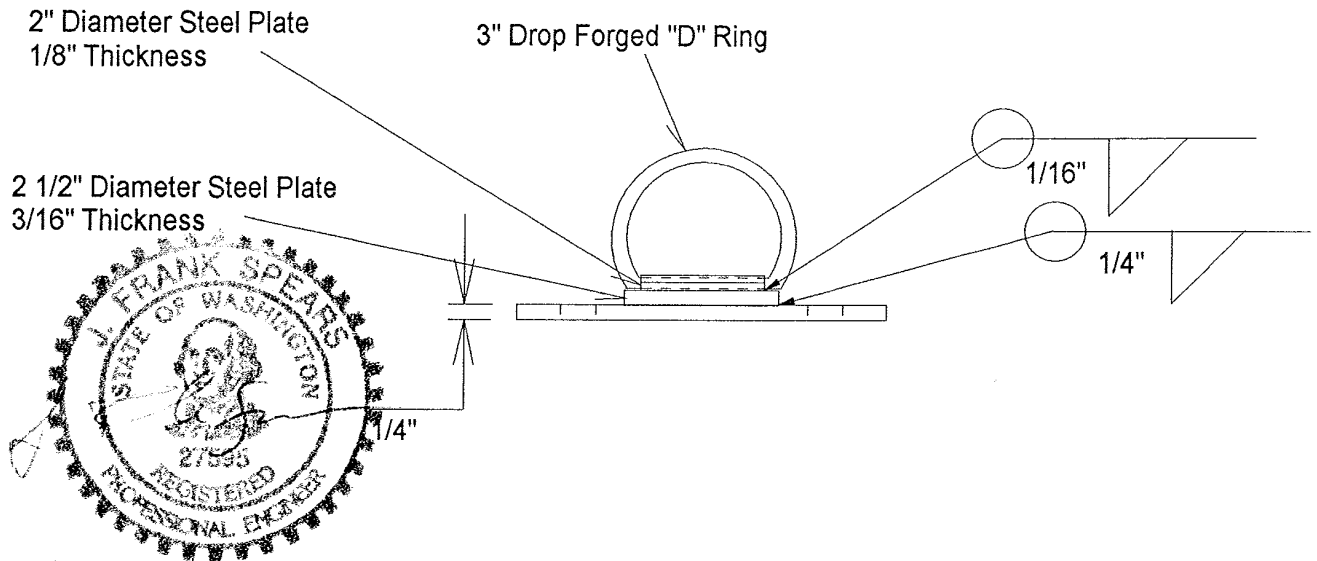

Notes:

EXPIRES 6-16-99

Steel Base plate shall be 1/4" hot rolled steel plate that meets ASTM A-570 specifications

2 1/2" diameter steel plate, 3/16" thick attached to base plate using 1/4" fillet weld.

2" diameter formed steel plate, 1/8" thick used to attached "D" ring to the 2 1/2" diameter steel plate using a 1/16" fillet weld.

Base plate can be bolted to concrete, steel, or wood as needed per application.

Anchor bolts shall be 1/2" diameter anchor bolts.

Anchor Bolts shall sustain a minimum ultimate pull-out load of at least 6,000 pounds.

Welding shall be performed by a certified welder using E-70xx rod or wire feed.

Top View

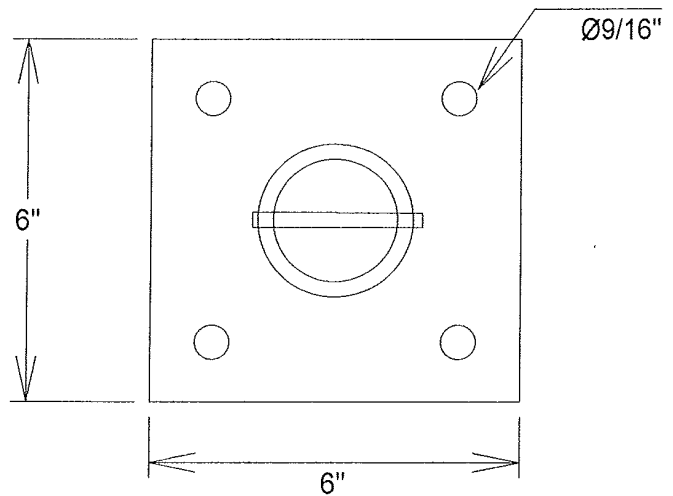

Project:
Guardian Metal Products
C.B. Series Fall Protection
CB-1B Bolt anchored

**SPEARS
ENGINEERING &
TECHNICAL
SERVICES**

P.O. Box 1007
Auburn, WA 98071-1007
(206) 833-7967

Civil Engineering - Geotechnical Engineering - OA/OC Services

Date:
8/22/97

Scale:
n/a

Sheet of
3 4

SETS' File & Report #:
96002-024